

DIGITUS Universal LED/LCD Monitor Stand with gas spring

DA-90365
EAN 4016032433996



Table stand for LCD/LED monitor up to 27" flexible gas spring mount, max 6,5kg, VESA 100x100

The universal table stand allows you to install LED and LCD monitors of all brands, in sizes up to 69 cm (27"). The gas spring arm allows you to adjust your monitor to whatever height you like. Simply note the VESA size and the weight of your monitor in order to select an appropriate table mount.

Universal table mount with gas spring for adjusting your monitor flexibly on four levels

- Integrated cable organizer
- Suitable for standard VESA mounting patterns of 75 x 75 and 100 x 100 mm

- Mount devices with a screen diagonal of 43 cm (17") to 69 cm (27") on a table
- Max. load bearing capacity: 6,5 kg
- Weight: 3,2 kg
- Dimensions: 420 x 250 x 380 mm
- Monitor weight (max.): 6 kg
- Mounting method: Stand
- Number of monitors: 1
- Size of monitors: up to 27"
- VESA mount: 75x75 mm, 100x100 mm

Package contents

- Monitor stand
- incl. mounting screws
- Operating instructions

Logistics						
	Number (pcs)	Weight (kg)	Depth (cm)	Width (cm)	Height (cm)	cm ³
Packaging Unit Carton	4	15.28	36.50	60.00	23.30	51,027.00
Packaging Unit Inside	1	3.82	28.80	34.50	9.80	9,737.28
Packaging Unit Single	1	3.82	28.80	34.50	9.80	9,737.28
Net single without Packaging	1	3.38	28.80	34.50	9.80	9,737.28

More images:

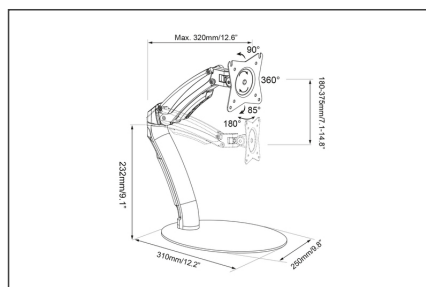

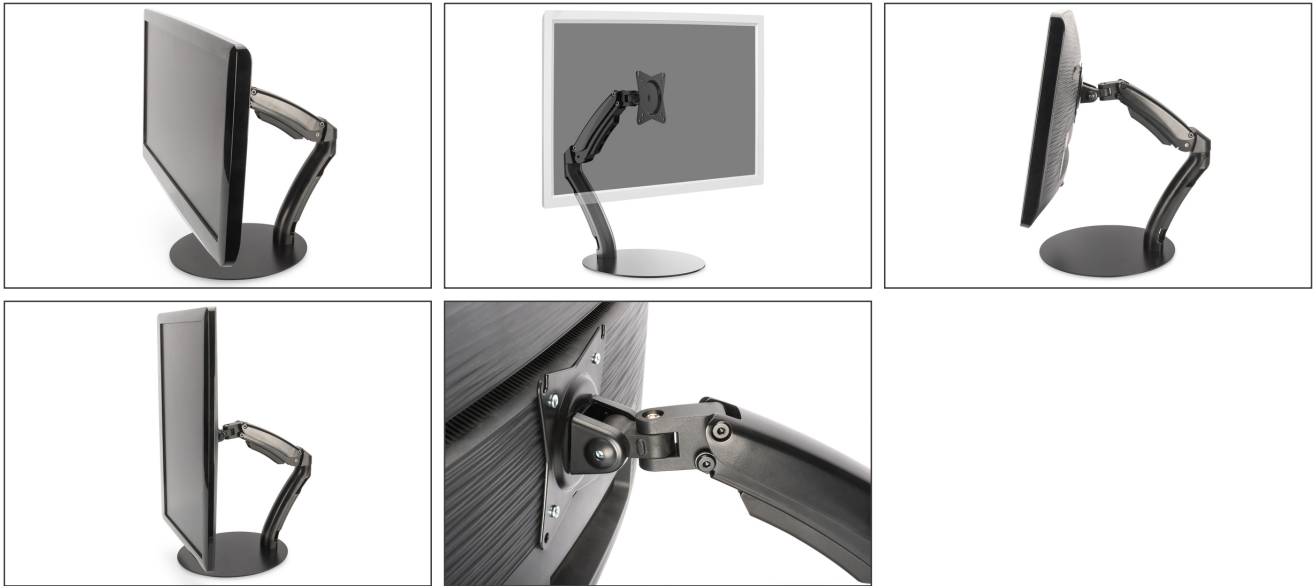

Safety notes

- Please read the entire manual before starting assembly and installation. Please contact your local dealer if you have any questions about the instructions or warnings.
- CAUTION: Use with products that exceed the permitted weight may result in damage or possible injury.
- Brackets should be fitted in accordance with the installation instructions. Incorrect installation can result in damage or injury.
- Use safety equipment and suitable tools. The product should only be installed by specialists.
- This product can be installed on timber-framed, solid concrete or stone walls.
- The load-bearing surfaces should be able to safely withstand the entire weight of appliances and all additional components.
- Only use the installation screws supplied and DO NOT TIGHTEN the screws TOO TIGHT.
- This product contains small parts that can cause a choking hazard if swallowed. Keep these parts away from children.
- Only use this product indoors. Using the product outdoors can lead to injury and damage.
- IMPORTANT: Before installation, please check all components received against the components list. If parts are damaged or missing, ask your local dealer for replacement parts.
- MAINTENANCE: Check the bracket regularly for safety and stability (preferably every three months).

EU responsible person

EU based economic operator ensuring the product complies with the required regulations.

ASSMANN Electronic GmbH
Auf dem Schüffel 3
Lüdenscheid, Germany
<https://www.assmann.com>
info@assmann.com