

DIGITUS Workstation (monitor, keyboard, mouse) Wall Mount

DA-90354
EAN 4016032383161

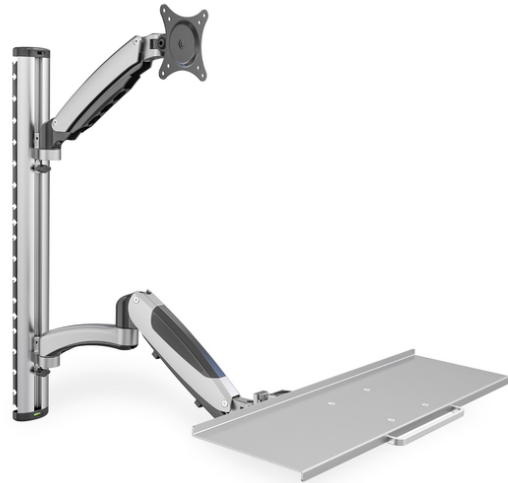

Workstation (Monitor, Keyboard) Wall Mount 27 inch, 6 kg, VESA 75x75, 100x100, silver

Universal wall mount with flexible working height adjustment for mounting monitors and keyboards. Set up a workspace that people of various different heights can use – you can easily adjust the working height with just two quick motions. Simply note the VESA size and the weight of your monitor in order to select a suitable mount.

Universal mount with flexible height adjustment for mounting monitors and keyboards to the wall

- Integrated cable routing

- Suitable for standard VESA mounting patterns of 75 x 75 and 100 x 100 mm
- Max. load bearing capacity: 6 kg per arm
- Weight: 4.2 kg
- Dimensions: 700 x 700 x 520 mm
- Style: PC Workstation

Package contents

- Wall mount
- Screws for mounting the monitor
- Operating instructions

Logistics						
	Number (pcs)	Weight (kg)	Depth (cm)	Width (cm)	Height (cm)	cm ³
Packaging Unit Carton	2	12.66	78.00	25.50	23.00	45,747.00
Packaging Unit Inside	1	6.33	76.50	23.00	10.00	17,595.00
Packaging Unit Single	1	6.33	76.50	23.00	10.00	17,595.00
Net single without Packaging	1	4.82	83.40	73.00	60.00	0.00

More images:

